

The Technology of Modern Filtration

Filters Designed and Built for Today's Industries



KELTEC
Technolab



TABLE OF CONTENTS

Conventional Wrap Style OIL SEPARATORS	4-5
Pleated Air-Oil SEPARATORS	6-7
Deep Filter OIL SEPARATORS	8-9
Spin-on Type OIL SEPARATORS	10-11
Refrigeration & Natural Gas OIL SEPARATORS	12-13
Oil Filters OIL FILTERS	14-15
Coalescing FILTERS	16-17
Synthetic LUBRICANTS	18-19
Compressed AIR FILTERS	20-21
Compressed AIR FILTERS	22-23
Panel Filter ELEMENTS	24-25
Additional PRODUCTS	26-27
HVAC FILTERS	28-29
Common Kits ROTARY SCREW COMPRESSORS	30

KELTEC Technolab, Inc.
2300 E. Enterprise Parkway
Twinsburg, OH 44087, U.S.A.
1 - 8 0 0 - 2 8 9 - 7 3 7 7
(330) 425-3100
Fax (330) 425-3550
sales@keltecinc.com
www.keltecinc.com



Compressed air and gas is essential in many industries for its use in equipment operation, instrumentation, refrigeration and a variety of industrial processes. Clean, oil-free air or gas is a requirement to reduce maintenance and replacement costs. Unfortunately, even atmospheric air contains objectionable contaminants, in both solid and liquid forms, that must be removed prior to the use of the compressed gas. Additionally, in many compressor and vacuum packages, oil is intentionally introduced as a coolant and sealant which must also be taken out prior to air use.

KELTEC Technolab manufactures a wide range of air-oil separators for air compressors and vacuum packages, as well as air inlet, oil and coalescing type filters, that when used together, provide the ultimate in system operation and protection.

KELTEC Technolab oil separators operate on the familiar principles of fine liquid droplet coalescence in a flowing gas stream. These processes have been refined and tailored into packages that meet the special high performance and physical requirements of the air/gas compressor industry.

Regardless of style (conventional, pleated or deep), KELTEC Technolab oil separators will provide for performance as shown here:

Pressure drop (at load): 2-3 psi / .20 bar

Pressure resistance (against collapse): 70 psi / 5.0 bar

Efficiency (remaining oil in gas stream): 2-3 ppm / 2-3 mg/m³

Operating temperature: (standard) 180° F / 82° C to 230° F / 110° C
(Higher temperature models available)

Materials: A. Media—both wet laid and high loft solely or in combination
B. Bonding compound—polyurethane or epoxy
C. Body components—corrosion resistant steel

Service life: Dependent mainly upon the cleanliness of the oil and gas being compressed as well as the initial amount of oil contained in the gas stream; several thousands of hours of operation are possible in a well-functioning compressor or vacuum system.



The standard conventional oil separator is the original design for the removal of oil aerosols from the compressed air stream. This element design consists of a specific amount of a uniform grade of borosilicate glass fibers, “wrapped” onto a support tube. When properly sized to the cfm/m³/min flowrate and corresponding operating pressure of the machine, this element will provide consistent performance according to the following data:

A. Pressure drop (initial)

2–3 psi / .20 bar

B. Pressure resistance

70 psi / 5 bar

C. Efficiency

2–3 ppm / 2–3mg/m³ residual oil



Conventional Wrap Style OIL SEPARATORS

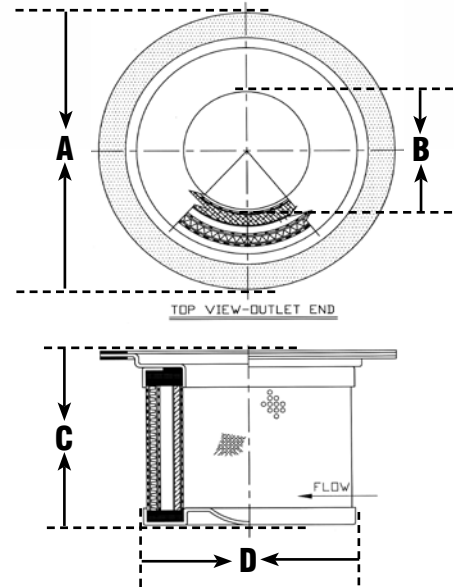

Conventional Wrap Style Oil Separators

Part No.	Capacity		A	B	C	D
	cfm	m3/m	Flange OD inches / mm	Flange ID inches / mm	Length inches / mm	Body OD inches / mm
KV70-032	70	2.00	6.69 / 170	3.46 / 88	8.35 / 212	5.31 / 135
KV110-010	124	3.50	6.69 / 170	3.46 / 88	12.48 / 317	5.31 / 135
KV200-042	124	3.50	7.87 / 200	4.84 / 123	9.53 / 242	6.69 / 170
KV150-019	159	4.50	7.87 / 200	4.84 / 123	12.48 / 317	6.69 / 170
KV210-009	230	6.50	7.78 / 200	4.84 / 123	17.60 / 447	6.69 / 170
KV240-007	282	8.00	12.60 / 328	8.66 / 220	12.48 / 317	10.82 / 275
KV280-010	318	9.00	10.79 / 274	6.50 / 165	16.60 / 447	8.66 / 220
KV425-003	424	12.00	12.91 / 328	8.66 / 220	18.19 / 462	10.83 / 275
KV400-006	424	12.00	10.79 / 274	6.50 / 165	24.09 / 612	8.66 / 220
KH500-016	495	14.00	13.98 / 355	9.65 / 245	20.16 / 512	11.81 / 300
KV600-019	600	17.00	13.98 / 355	9.65 / 245	24.09 / 612	11.81 / 300
KV670-004	671	19.00	13.98 / 355	9.65 / 245	26.46 / 672	11.81 / 300
KV610-002	706	20.00	12.76 / 324	8.66 / 220	30.00 / 762	10.83 / 275
KV880-001	848	24.00	13.98 / 355	9.65 / 245	32.76 / 832	11.81 / 300
KV1050-001	1024	29.00	13.98 / 355	9.66 / 245	39.84 / 1012	11.81 / 300
KV1300-019	1483	42.00	22.40 / 570	15.75 / 400	36.22 / 920	18.70 / 475



One common method of increasing the capacity of a given sized air-oil separator is through the use of pleated filter media. In this case, the filter media is processed through a machine whereby the normally flat surface is “pleated” or induced into a wave-like appearance. A separator configured in this manner can then be suited for approximately 2x the air flow capacity, as that of a standard air-oil separator, manufactured in the standard, wrapped method.



Pleated Air-Oil SEPARATORS

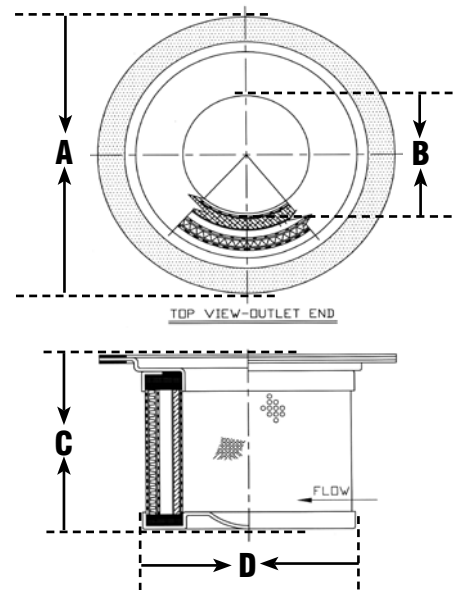

Pleated Air-Oil Separators						
Part No.	Capacity		A	B	C	D
	cfm	m ³ /m	Flange OD	Flange ID	Length	Body OD
			inches / mm	inches / mm	inches / mm	inches / mm
KV150-013P	150	4	7.88 / 200	3.88 / 99	6.81 / 173	6.75 / 171
KV210-004P	210	6	7.88 / 200	3.88 / 99	9.88 / 251	6.75 / 171
KV525-001P	525	15	10.66 / 271	5.25 / 133	16.00 / 406	8.38 / 213
KV820-001P	820	23	10.66 / 271	5.25 / 133	24.00 / 610	8.38 / 213
KV1970-001P	1970	56	23.75 / 603	15.00 / 381	22.25 / 565	19.00 / 483
KV3000-001P	3000	250	23.25 / 591	15.00 / 381	36.25 / 921	19.00 / 483



Another common method of obtaining increased air flow capacity from a given size air-oil separator is to manufacture the element in so-called “deep filter” construction. This form of separator uses as many as three different grades of borosilicate glass, wrapped onto the support tube in larger than normal amounts. The finished product then achieves increased airflow capacity very similar to that of the pleated air-oil separator, while at the same time maintaining low initial pressure drop and residual oil content. Field testing of this element has demonstrated an improvement in oil separation especially in high “challenge rate” applications, in which more oil aerosol is contained in the compressed air than is normal.

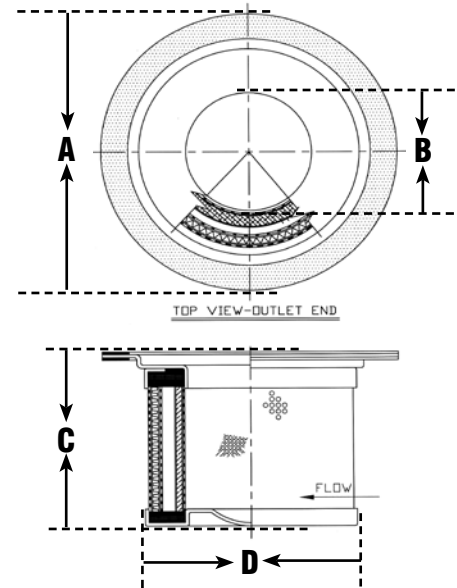

Deep Filter Type Oil Separators					
		A	B	C	D
Part No.	Capacity	Flange OD	Flange ID	Length	Body OD
	cfm / m3/min	inches / mm	inches / mm	inches / mm	inches / mm
KV61-011	125 / 3.54	8.66 / 220	2.95 / 75	6.30 / 160	5.31 / 135
KV66-012	160 / 4.53	6.69 / 170	2.95 / 75	7.87 / 200	5.31 / 135
KV100-027	230 / 6.51	7.87 / 200	4.29 / 109	9.06 / 230	6.69 / 170
KV150-034	320 / 9.06	7.87 / 200	4.29 / 109	12.00 / 305	6.69 / 170
KV265-018	565 / 16.00	13.98 / 355	8.66 / 220	12.00 / 305	11.81 / 300
KV335-006	705 / 19.97	12.91 / 328	8.23 / 209	15.75 / 400	10.83 / 275
KV350-022	775 / 21.95	13.98 / 355	8.66 / 220	15.75 / 400	11.81 / 300
KV440-013	990 / 28.04	13.98 / 355	8.66 / 220	19.69 / 500	11.81 / 300
KV535-003	1200 / 33.98	13.98 / 355	8.66 / 220	23.62 / 600	11.81 / 300
KV625-012	1425 / 40.36	13.98 / 355	8.66 / 220	27.56 / 700	11.81 / 300



This method of oil separation consists of a deep bed type oil separator element, placed inside of a pressure resistant body, or “can” similar to that of traditional oil filters. Extremely easy to replace in comparison to standard oil-separators which are enclosed in a pressurized tank, this element design is somewhat limited in application due to restrictions of air flow capacity.



Spin-on Type

OIL SEPARATORS

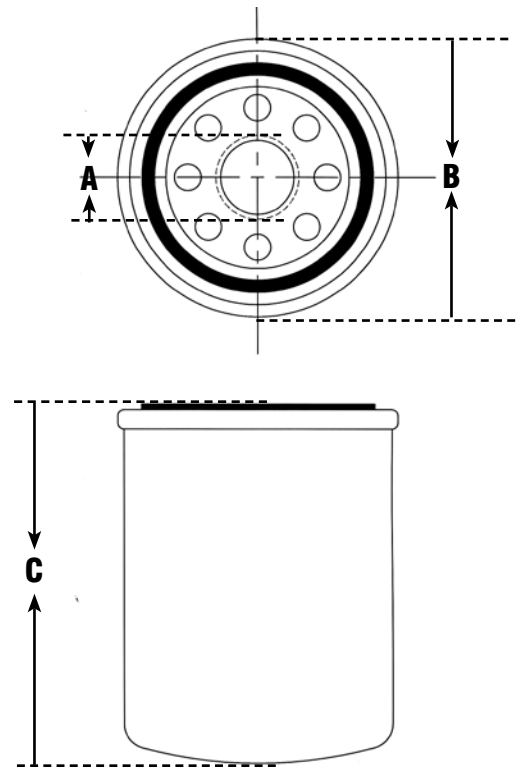

Spin-on Type Oil Separators				
		A	B	C
Part No.	Flow Rate cfm	Thread m3/m	Body Diameter inches / mm	Length inches / mm
KD490-006	35.00 / 1.00	m22 x 1.5	2.99 / 76	5.00 / 127
KD610-008	70.00 / 2.00	m24 x 1.5	3.66 / 93	8.35 / 212
KD710-009	106.00 / 3.00	m39 x 1.5	5.35 / 136	6.97 / 177
KD690-006	141.00 / 4.00	m32 x 1.5	4.25 / 108	10.24 / 260
KD900-018	194.00 / 5.50	m39 x 1.5	5.35 / 136	11.89 / 302



Special inorganic materials are required for the construction of properly functioning oil separators in refrigeration and natural gas compressor packages. In these units, gases other than air (such as Freon, ammonia or natural gas) are being compressed and mixed with lubricating oil which still must be removed prior to use of the gas. These types of gases, along with ancillary materials often contained in natural gas, are not suitable for typical oil separator construction, and care must be given to the proper selection of all materials in order to ensure proper functioning of the separator.

Refrigeration & Natural Gas OIL SEPARATORS

KELTEC Technolab has the longest history of successful oil separation technology for this field. From the coalescing materials to the sealing methods used, you can be confident in oil separators for refrigeration and natural gas purchased from KELTEC Technolab. A wide range of standard sizes are available, as well as a broad capability to produce elements custom-suited for your specific application.

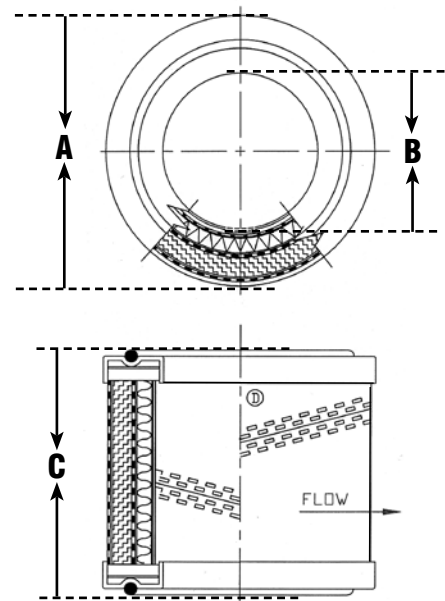

Refrigeration & Natural Gas Oil Separators			
	A	B	C
Part No.	OD	ID	Length
	inches / mm	inches / mm	inches / mm
KR1100-005P	9.40 / 239	6.12 / 155	34.00 / 864
KR435-006P	9.40 / 239	6.12 / 155	28.00 / 711
KR770-008P	9.40 / 239	6.12 / 155	24.00 / 610
KR325-015P	9.40 / 239	6.12 / 155	18.00 / 457
KR500-018P	9.40 / 239	6.12 / 155	16.25 / 413
KR375-022P	7.00 / 179	4.00 / 102	18.00 / 457
KR385-014P	7.00 / 179	4.00 / 102	12.00 / 305



In the compressor system, the oil itself must be filtered on a regular cycle so as to remove contaminants that may enter the compressor and damage the unit. This is accomplished through the installation of a lube oil filter, either in cartridge, or spin-on form, which then ensures that all of the oil is cleaned as it moves through the filter.

Filtering in 5–25 micron range (depending upon application), it is again, the depositing of oil-borne contaminants over time (similar to the oil-separator), that causes the oil filter to continually increase in differential pressure to a point at which it must be replaced in order to continue proper filtration of the compressor oil.



Like all of our products, KELTEC Technolab oil filters are built of the highest quality materials and workmanship. Specific filtration levels are obtained through the exclusive use of high grade filter media and consistent surface area control, obtained by a strict maintenance of pleat quantity and depth. Leakages are prevented by the positive seals obtained with both plastisol and epoxy encapsulation. Viton seals are used where applications of synthetic oil are typical.

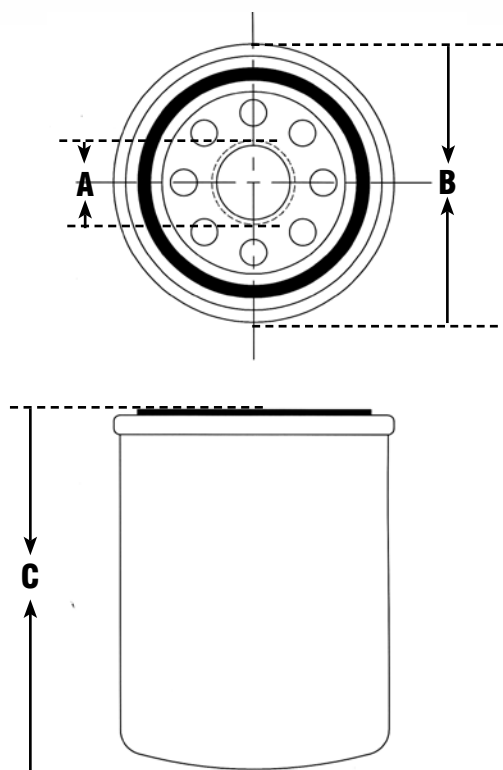

Oil Filters				
Part No.	Capacity (gallons/liters/min.)	A Thread	B OD inches / mm	C Length inches / mm
KL310-017	2.17 / 12.00	3/4-16	3.15 / 80.00	3.66 / 93.00
KL470-008	5.00 / 20.00	3/4-16	3.15 / 80.00	5.50 / 140.00
KL510-016	10.50 / 40.00	1-12	3.78 / 96.00	6.77 / 172.00
KL320-004	10.50 / 40.00	3/4-16	3.78 / 96.00	5.50 / 140.00
KL460-009	10.50 / 40.00	1-12	3.78 / 96.00	5.50 / 140.00
KL135-035	11.89 / 45.00	1-12	3.78 / 96.00	6.77 / 172.00
KL440-015	18.50 / 70.00	1-12	3.78 / 96.00	8.30 / 210.00
KL590-007	18.50 / 70.00	1-12	4.33 / 110.00	8.94 / 227.00
KL800-020	47.50 / 180.00	1-1/2-16	5.50 / 140.00	11.89 / 302.00



Once generated by the air compressor, (compressed) air often must be further filtered so as to meet the exacting needs of the industrial applications for which it is used. This is most effectively done through the use of a downstream coalescing filter, or series of filters. It is a common misconception that “oil-free” air compressors do not require this precaution. However, atmospheric air typically contains a significant amount of water, oil vapor and other contaminants, especially in industrial areas.

Upon compression, therefore, these contaminants are concentrated into the compressed air, whether the machine is “oil-free” or oil-flooded. Accordingly, the use of fine, coalescing filters is essential for both types of compressors, so as to prevent an accumulation of such contaminants in pneumatic machinery.



Coalescing FILTERS



KELTEC Technolab coalescing filters are the simple way to avoid such contamination in your expensive equipment. Our filters provide the highest level of clean, compressed air with a minimum loss of energy (pressure drop). Through the selection of the appropriate grade of borosilicate microglass filtration media, and maintaining the quantity, diameter, and direction of individual fibers, KELTEC Technolab coalescing filters guarantee your air compressor system will operate correctly with minimal operational upkeep.



SOME STANDARD PART NO.'S (Coalescing Filters)

KELTEC Technolab PN	Length		OD	
	inches	mm	inches	mm
KPFEK06 *	2.64	67	1.38	35
KPFEK13 *	3.27	83	1.97	50
KPFEK25 *	4.72	120	1.97	50
KPFEK40 *	6.30	160	2.83	72
KPFEK85 *	10.24	260	2.83	72
KPFEK195 *	12.99	330	3.39	86
KPFEK295 *	24.92	633	3.39	86
KPFEK400 *	16.37	416	4.49	114
KPFEK500 *	25.08	637	4.49	114

* The following grades are available:

AOVE-CBM 99.97% 1 micron

AAYE-CB 99.97% .01 micron

AC-AB oil vapor and odor removal



KELTEC Technolab offers a full range of PAO, diester and polyglycol based compressor lubricants, designed to match the most difficult compressor application. Continual testing and research combines to ensure that the most effective oil additives are used in order to virtually eliminate such common problems as foaming, oxidation, and deposit formation. Listed on the next page are some examples of available lubricants along with their typical properties.



SYNTHETIC LUBRICANTS				
KOA467C	PAO Base Oil			
	Viscosity	SUS @	35° C / 100° F	49
		SUS @	100° C / 210° F	8
	ISO Viscosity Index			46
	Flash Point		230° C / 450° F	
	Autoignition Temp.		420° C / 785° F	
	Pour Point		-3° C / -38° F	
	Copper Corrosion			1A
	Thermal Oxidation Test			.20
KOA680C	Diester Base Oil			
	Viscosity	SUS @	35° C / 100° F	64
		SUS @	100° C / 210° F	8
	ISO Viscosity Index			86
	Flash Point		250° C / 480° F	
	Autoignition Temp.		420° C / 790° F	
	Pour Point		-7° C / -45° F	
KPGRS	Polyglycol / Ester Base Oil			
	Viscosity	SUS @	35° C / 100° F	216
		SUS @	200° C / 210° F	52
	ISO Viscosity Index			140
	Flash Point		260° C / 500° F	
	Autoignition Temp.		400° C / 750° F	
	Pour Point		-13° C / -55° F	

COMPRESSED AIR CONTAMINATION

Even in today's high-tech world, compressed air remains the primary power source for industry. Because it has many advantages over other types of energy, an increasing number of applications for compressed air are still being discovered.

Unfortunately, compressed air is subject to contamination from the atmosphere and the compressor itself. This results in corrosion and other related problems, which inevitably lead to system and equipment failure.

THE KELTEC Technolab SOLUTION:

The Ultimate in Compressed Air Filtration

When it comes to keeping compressed air clean and oil-free, no one fits the bill like KELTEC Technolab. KELTEC Technolab's advanced line of coalescing filters for compressed air systems offers a rare blend of exceptional performance, proven reliability and uncommon value.

The KELTEC Technolab compressed air filter product line covers a full range of products to handle virtually any flow rate and operating condition. Our array of high-efficiency coalescers, particulate/general purpose coalescers, and adsorptive carbon filters offers solutions to virtually all compressed air filtration applications.





Compressed AIR FILTERS

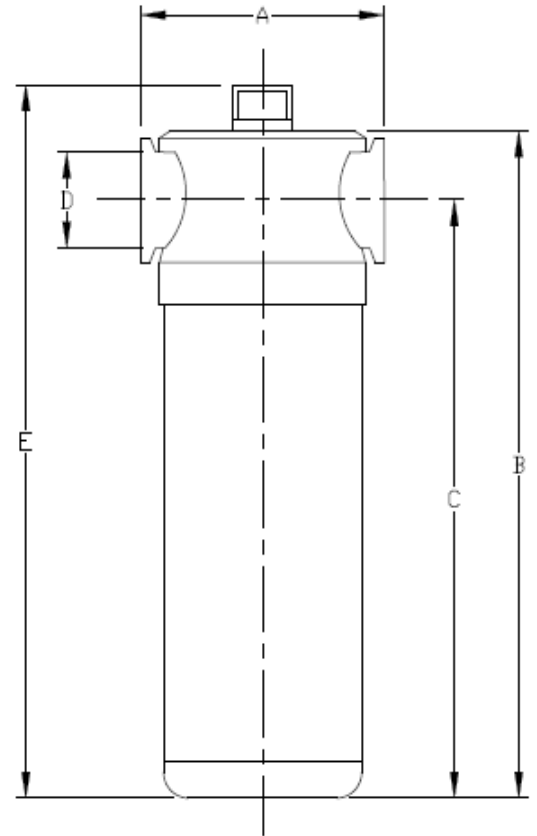

PART NUMBER	Housing Dimensions					CFM (M ³ /H)	PSI (BAR)	Element (P/X/Y/A)				
	A		B		C				D	E		
	INCHES / MM	INCHES / MM	INCHES / MM	INCHES / MM	INCHES / MM							
CAH-0058-BSP/NPT	4.00	102	10.12	257.5	9.28	235.5	1/2"	11.98	304.5	58(100)	290(20)	KP0058
CAH-0088-BSP/NPT	4.84	123	11.91	302.5	10.84	275.5	3/4"	13.75	349.5	88(150)	290(20)	KP0088
CAH-0117-BSP/NPT	4.84	123	14.44	366.5	13.38	339.5	3/4"	16.28	413.5	117(200)	290(20)	KP0117
CAH-0147-BSP/NPT	4.84	123	16.00	406.5	14.94	379.5	1"	17.86	453.5	147(250)	290(20)	KP0147
CAH-0353-BSP/NPT	4.84	123	21.18	538	19.75	502.5	1-1/2"	23.03	585	353(600)	290(20)	KP0353
CAH-0500-BSP/NPT	6.30	160	24.62	625.5	23.00	584	2"	26.48	672.5	500(851)	290(20)	KP0500
CAH-0712-BSP/NPT	6.30	160	27.38	695.5	25.75	654	2"	29.25	742.5	71(1210)	290(20)	KP0712
CAH-0930-BSP/NPT	7.64	194	28.75	730	26.46	672	2-1/2"	30.62	777	930(1550)	232(16)	KP0930
CAH-1140-BSP/NPT	7.64	194	34.25	869.5	31.98	812.5	3"	36.08	916.5	1140(1900)	232(16)	KP1140
CAH-1380-BSP/NPT	7.64	194	36.38	924	34.12	867	3"	38.25	971	1380(2300)	232(16)	KP1380

NOTE: CAH-0930 REPLACE CAH-0888
 CAH-1140 REPLACE CAH-1065
 CAH-1380 REPLACE CAH-1300

Housings can be fitted together with the use of Fixing clamps.



Clamp Numbers	Housings
CAH-CL050	CAH-0058
CAH-CL075-125	CAH-0088
	CAH-0117
	CAH-0147
CAH-CL150	CAH-0353
CAH-CL200	CAH-0500
	CAH-0712
CAH-CL250-300	CAH-0930
	CAH-1140
	CAH-1380



3 Drain Options

CAH-ED(NPT or BSP)-ASSY

Heavy duty external drain that can be easily attached to the CAH-BHF050F Bulkhead Fitting (shown) and housing.



#CAH-ADMD

Auto/manual drain
(included standard with every housing)

SDV115V-25AN and SDV220V-50AN

Solenoid operated electronic drain valves come COMPLETE WITH STRAINER that can be easily attached to the CAH-BHF050F Bulkhead Fitting (shown) and housing.





- Interchanges for all manufacturers
- Rugged industrial construction
- Galvanized steel frames
- Metal straps for ease of removal
- Metal support screens—both sides
- Huge inventory
- Competitive pricing



Panel Filter ELEMENTS



KA 093

- 24" x 24" x 1.5" nominal
- 23.5" x 23.5" x 1.5" actual
- Galvanized frame
- Polyester felt media
- Washable
- 2500 SCFM
- .57" W.C. Δ P
- 10 micron–98% efficiency



KA 005

- 24" x 24" x 2" nominal
- 23.5" x 23.5" x 2" actual
- Galvanized frame
- Polyester felt media
- Washable
- 2500 SCFM
- 1.1" W.C. Δ P
- 10 micron–98% efficiency



KA 099

- 24" x 24" x 2" nominal
- 23.5" x 23.5" x 2" actual
- Galvanized frame
- Polyester felt media
- Washable
- 1250 SCFM
- .5" W.C. Δ P
- 4 micron–98% efficiency



KA 176

- 24" x 24" x 6" nominal
- 23.4" x 23.4" x 5-7/8" actual
- Galvanized frame
- Microglass media
- 1250 SCFM
- .5" W.C. Δ P
- 5 micron–98% efficiency



KA 164

- 24" x 24" x 12" nominal
- 23.4" x 23.4" x 11.5" actual
- Galvanized frame
- Microglass media
- 2500 SCFM
- .9" W.C. Δ P
- 2 micron–99.7% efficiency



KA 166

- 24" x 24" x 12" nominal
- 23.4" x 23.4" x 11.5" actual
- Galvanized frame
- Microglass media
- 1250 SCFM
- 1.0" W.C. Δ P
- .3 micron–99.97% efficiency



KA 771

- 18" x 18" x 12" nominal
- 17.5" x 17.5" x 11.62" actual
- Galvanized frame
- Microglass media
- 1250 SCFM
- .9" W.C. Δ P
- 2 micron–99.97% efficiency



KA 770

- 18" x 18" x 2" nominal
- 17.62" x 17.62" x 2" actual
- Galvanized frame
- Polyester felt media
- Washable
- 1250 SCFM
- .7" W.C. Δ P
- 10 micron–99% efficiency

KELTEC Technolab produces a wide range of additional filter products, including:

- **Air filters for compressors**
- **Air filters for vacuums**
- **Oil separators for vacuums**

Air filters are produced with either resin impregnated cellulose or synthetic polyester filter media, in either plastisol (rubber) or metal end construction, as well as the latest type, metal-free air intake filters.

Oil separators for vacuum packages are constructed similar to that of the standard oil separators used in air compressors, and thus, will offer the same type of oil removal performance (in the range of 1–3 ppm / 1–3 mg/m³). However, such separators are designed exclusively for flow direction from the outside to the inside of the separator, and are suitable only to a maximum pressure differential (collapse point) of 22 psi / 1.5 bar.





Trouble with oil carryover?

Trouble with high pressure drop?

Introducing KELTEC Technolab
GOLD air oil separators!
(Sold exclusively to OEM's.)

The KELTEC Technolab GOLD separator can reduce oil carryover and pressure drop by up to 50% from a similarly sized standard pleated air-oil separator, and can often times be fitted into an existing separator size.

Contact KELTEC Technolab today for more information on GOLD air oil separators.

1-800-289-7377
(330) 425-3100
Fax (330) 425-3550
sales@kelttecinc.com
www.kelttecinc.com



KELTEC Technolab, Inc.
2300 E. Enterprise Parkway
Twinsburg, OH 44087, U.S.A.

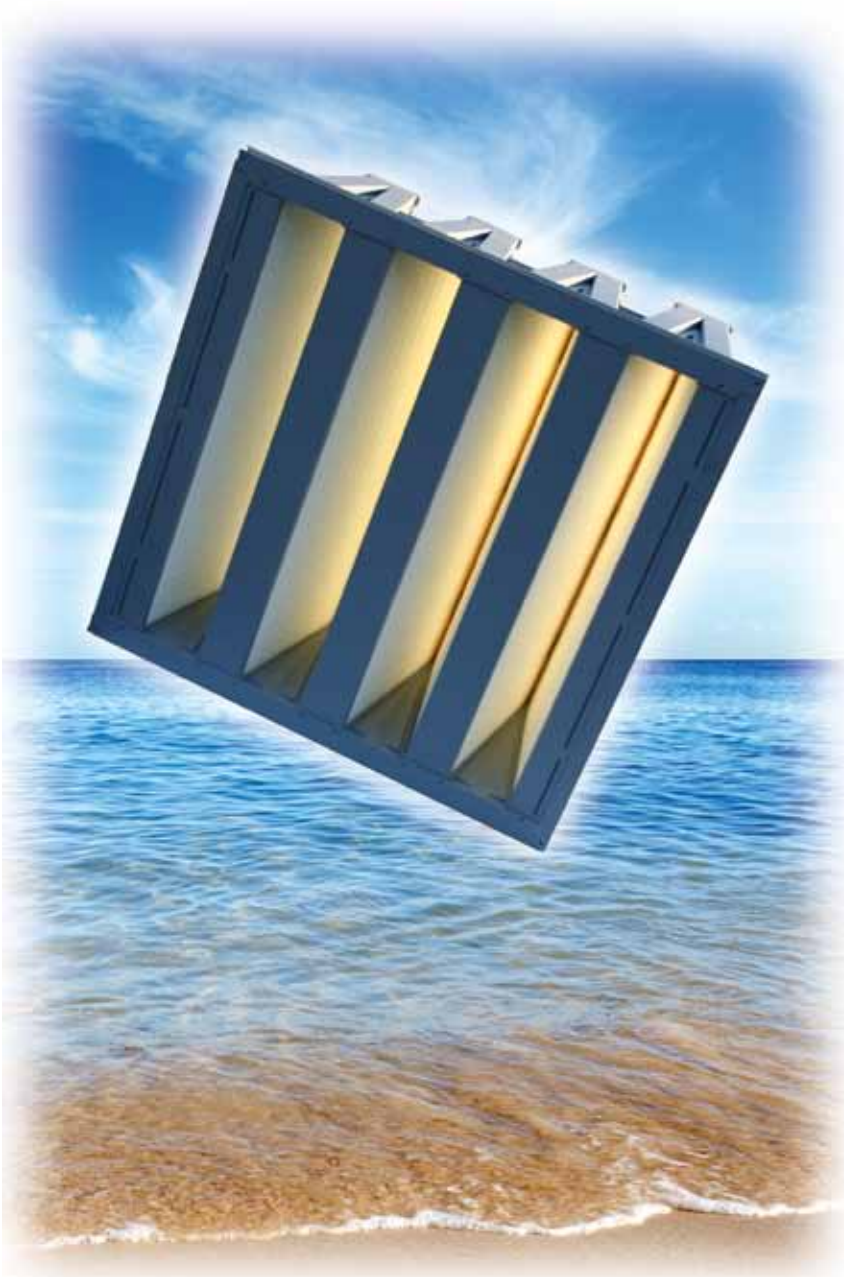

High efficiency ASHRAE filter for HVAC applications

Hydrophobic glass fiber “mini-pleat” design in “V-bank” configuration for the maximum amount of filter media, providing for superior dust-holding capacity with exceptionally low pressure drop.

Pleat spacing and uniformity is assured with physical division of each individual pleat, assuring equal and smooth airflow through the filter media.

Tough, durable molded plastic frame to resist damage during use and transportation.



HVAC FILTERS



DESIGN CHARACTERISTICS (All Four Models)

Size	23.30" x 23.30" x 11.49"	592mm x 592mm x 292mm
Filter Surface Area	194 ft ²	18m ²
Airflow	2500 cfm	4250m ³ /h
Maximum Temperature	160°F	70°C

ELEMENT SPECIFICATIONS

ASHRAE	MERV	EUROVENT	Initial Pressure Drop	Final Pressure Drop
HVAC2412-11	11	F6	.40"/100 PASCALS	6.10"/1519 PASCALS
HVAC2412-13	13	F7	.46"/115 PASCALS	6.10"/1519 PASCALS
HVAC2412-14	14	F8	.50"/125 PASCALS	6.10"/1519 PASCALS
HVAC2412-15	15	F9	.62"/155 PASCALS	6.10"/1519 PASCALS



If your popular item isn't here, let us know, and we'll find it for you!



KELTEC

Technolab



Keltec-Technolab guarantees that its filters will meet or exceed the specifications and performance of the OEM, and further, that customers replacing OEM filters with Keltec-Technolab filters will experience no filter-related difficulty.



KELTEC

Technolab



KELTEC Technolab compressor filters and oil are suitable replacements for all major competitive interchanges. The technical characteristics of KELTEC Technolab products can be found within this guide. KELTEC Technolab filters have successfully replaced all other major brands of OEM and replacement filters in literally tens of thousands of applications.

KELTEC Technolab, Inc.

2300 E. Enterprise Parkway

Twinsburg, OH 44087, U.S.A.

1-800-289-7377 • (330) 425-3100

Fax (330) 425-3550 • sales@keltecinc.com

www.keltecinc.com